

# COMARRA

TELECOM TRANSMISSION SOLUTIONS

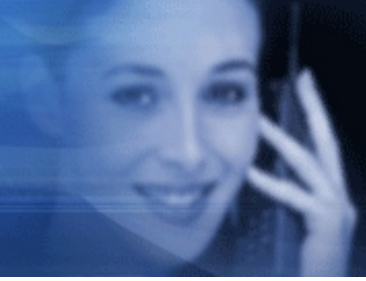

**VCL-EC™**

**Voice Quality Enhancement (VQE) &  
E1 Echo Canceller**

---

**8 x VQE & E1 Echo Cancellers per Chassis**

---

Product Brochure & Data Sheet

**COMARRA**

**E-Mail: [info@comarra.co.uk](mailto:info@comarra.co.uk)**

**Web Site: <http://www.comarra.co.uk>**

## INDEX

S. No.	Particulars	Pg. No.
1	Product Overview	3
2	Key Highlights	3
3	Echo Tail-Displacement (Echo Tail Off-Set)	4
4	Applications	5
5	Features and Highlights	6
6	Front View	8
7	Technical Specifications	9
8	Ordering Information	10
9	Support	11



## Product Overview

Comarra offers the industry's most compact 8xE1 voice quality enhancement (VQE) and echo canceller solution in a 19-inch, 1U (44mm height) chassis, with echo tail-displacement (echo tail off-set) feature which is user programmable from 0ms. to 512 ms. Echo cancellation on each channel is 128 ms. bidirectional (near-end and far-end) echo cancellation. The 8xE1 VQE and echo canceller solution offers a unique, user definable echo-tail displacement feature which may be programmed by the user, between 0ms. to 512ms. on the return path to cancel echo-tails, both at the near-end and the far-end, in the most demanding network conditions. T1 version of VQE and echo cancellers are also offered and available.



**8xVQE & E1 Echo Canceller**

Comarra offers echo cancellation and voice quality enhancement solutions for the following network situations:

- Wireline
- International Gateway
- IP Gateway
- Wireless
- Satellite

This solution is also an ideal echo cancellation solution for long distance telephony, GSM, CDMA, TDMA, VoIP, satellite and radio communication applications.

The VQE and echo canceller equipment is compliant to ITU-T G.168 (2000/2002) requirements for echo cancellation. The echo canceller solution offers carrier-grade voice quality per AT&T Voice Quality Assessment Lab. Echo cancellation on each channel is 128 ms. bidirectional.

## Key Highlights

- Comarra offers the industry's most compact 8 x voice quality enhancement (VQE) & E1 Echo Cancellers solution.
- 128 ms. bidirectional (near-end and far-end) echo cancellation with echo-tail displacement (tail-offset) from 0ms. to 512 ms.
- Programmable echo-tail displacement (echo tail off-set) from 0ms. to 512 ms.
- Echo-Tail Displacement allows the user to program a delay off-set on return path and user can cancel near-end and far-end echo from single installation.
- Ideally suited for GSM Networks to eliminate "background noise" to enable GSM Networks to function at half-rate (HR) (with full-rate voice quality) thereby doubling spectrum usage in GSM networks.
- Echo cancellation on each channel is 128 ms. bidirectional (near-end and far-end).
- Compliant to ITU-T G.164, G.165, G.168 (2000/2002) recommendations.
- Electrical Echo Cancellation resulting from networks delays and delays arising due to complex voice compression algorithms in hybrid PSTN and long distance networks.
- Acoustic Echo Cancellation required for mobile networks for cancelling echo-tails that originate from cellular hand-sets, designed with poorly designed acoustic feedback.
- Auto Voice Level Control and VQE (Voice Quality Enhancement features) required for reducing background noise from calls originating from crowded public places or other noisy environments and maintaining a uniform Voice level in a Network. Improves voice quality.
- User programmable dedicated data channels
- Remote access through Telnet
- 8 x E1 (or T1) VQE and echo cancellers in a 1 U (44mm) high chassis - industry's smallest foot print.
- User Programmable signaling options: R2, CAS, PRI ISDN (30B+D), C5, CCS, Q50(AB/CD), C7, SS7.

## Type of VQE and E1 Echo Canceller offered

8 x Voice Quality Enhancement (VQE) E1 Echo Cancellers 19 inch, 1U (44mm) chassis, 128ms. bidirectional echo cancellation tail. E1 inputs and outputs are balanced 120 Ohms, RJ-45.

### Question: What is echo tail-displacement (echo tail off-set)?

**Answer:** Echo tail-displacement (echo tail off-set) is an important feature used in bidirectional echo cancellation, to make it effective and useful for bidirectional echo cancellation.

**Explanation:** Bidirectional (defined as near-end and far-end automatic echo cancellation operation) echo cancellers have the capability of cancelling echoes in both directions (on the Transmit as well as the Receive paths), by installing them at a single location. Bidirectional echo cancellers can be installed at a single location, either the near-end or the far-end, and used to cancel both near-end and far-end echo-tails, from a single installation.

Usually, satellite links and intercontinental VoIP circuits have fixed network delays which exceed the capabilities of commonly available (192 ms.) echo cancellers for bidirectional echo cancellation, thus making them unsuitable for bidirectional echo cancellation.

**Example:** An inter-continental satellite or a VoIP link may have a fixed end-to-end round-trip delay of 300ms., thereby rendering all commonly available echo cancellers, with even 192 ms. echo cancellation capabilities, ineffective for bidirectional echo cancellation.

Using the Echo Tail-Displacement (echo tail off-set) feature, the user may off-set and account for the fixed round-trip network delay on the return path so that the echo cancellation window on the return-path is shifted (off-set) by 300 ms., so as to allow the bidirectional echo canceller to function effectively in both directions and to cancel both near-end, as well as the far-end echo-tails on the return path, even if the echo canceller is installed at the near-end in a given network.

Echo Tail-Displacement (echo tail off-set) allows the user to program a delay off-set on the return path, so that the user may cancel both near-end and far-end echo-tail with a single Echo Canceller installation. The echo tail-displacement allows the user to compensate for the fixed network delays on the return path of the echo-tail, so that the user can effectively cancel, both near-end and far-end echoes using a single Echo Canceller without being limited by the fixed end-to-end delay of that network link.

Comarra's Echo canceller has a user programmable "echo tail-end displacement" (echo tail off-set) from 0 ms. to 512 ms.

This feature allows the use of a single echo canceller installation to cancel echo-tails in both directions over inter-continental satellite or VoIP links where the fixed network delays are excessive (beyond and in excess of (example) 192 ms. echo cancellation capability of the commonly sold bidirectional echo canceller solutions).

**Question:** My Network has a total of 300 ms. end-to-end delay. How can I use a 128 ms. bidirectional echo canceller to cancel, both, near-end and far-end echoes?

**Answer:** The use of the "programmable echo tail-displacement" (echo tail off-set) feature in our echo cancellers allows the user to cancel echoes on the return path even if the network delays exceed 128 ms.

The fixed network delay shall be calculated ascertained and programmed as the "echo tail-displacement" on the return path. This shall allow the user to use a single echo canceller to cancel echoes, bidirectionally, even if the total network end-to-end delay is in excess of 300 ms.

The Comarra 128 ms., bidirectional echo canceller solution, equipped with a user programmable "echo tail-displacement" feature is superior than a simple single 192 ms. bidirectional echo canceller solution for cancelling both near-end and far-end echoes, even if the fixed round-trip network delays exceed 300 ms. (*please see the example above*).

## Applications for the VCL-EC

### Applications

- Wireless: GSM, CDMA, TDMA and Cellular Base Stations
- Digital Circuit Multiplication Equipment (DCME) : Satellite Communications and Multiplexers
- PCS, mobile and digital cordless wireless systems
- PBX and central office systems
- Datacomm: Voice over Frame Relay, Voice over ATM and Voice over Internet
- Voice over ATM, Frame Relay or packet switching systems and fax transmissions
- Central Office and PBX: Network Trunks, Echo Canceller Pool, Common Equipment and Audio Conferencing Bridges
- Voice over Datacomm including Voice over Internet (VoIP), Voice over ATM (VoATM) and Voice over Frame Relay (VoFR)

### Datacomm Applications

- Voice over Frame Relay
- Voice over ATM
- Voice over Internet/LAN

### Satellite Communications Applications

- Digital Circuit Multiplication Equipment

### Wireless Applications

- GSM, CDMA
- Cellular Base Stations

### Central Office and PBX Applications

- Network Trunks
- Echo Canceller Pool
- Common Equipment
- Audio Conferencing Bridges

### Voice Over ATM Applications

- A multi-channel echo canceller resource or pool is shared among many channels to reduce cost
- Echo cancellation is done at a DS0 level

### Voice over Frame Relay, ATM Applications

- Frame Relay and ATM routers and switches introduce large, variable and unpredictable delays
- Echoes from the Public Switched Telephone Network (PSTN) in combination with the delays from Frame Relay and ATM equipment yield objectionable speech quality

## VCL-EC 8 x VQE Echo Canceller per Chassis - Features

### Features

- **USER PROGRAMMABLE ECHO TAIL DISPLACEMENT (Echo tail off-set):** User definable echo-tail displacement is selectable between 0ms. to 512ms. on the return-path. This feature allows the user to cancel echo-tails in both directions (both near-end and far-end echo tails), even in most demanding conditions that are common on VoIP networks and satellite links.
- **USER PROGRAMMABLE SIGNALING OPTION:** The E1 Echo Canceller support the following signaling protocols: Signaling protocols supported:
  - 30B+D PRI ISDN (Euro ISDN) signaling
  - 31B (31 Voice Channels) with out-of-band signaling
  - R2 CAS signaling
  - SS7 signaling (on any user selected time-slot)
  - CAS C5, CCS, Q50 (AB/CD), C7, PRI ISDN (30B+D)
  - All signaling options are User Selectable/User Programmable
  - Allows digital data transmission on any individual user-selected time-slots
- The E1 Echo Canceller supports 2100 Hz fax/analog data modem tone detection and echo canceller disabling on all channels.
- **USER PROGRAMMABLE DEDICATED DATA CHANNELS:** The user may specify/define the dedicated data channels so that they are always and completely by-passed from the echo cancellation circuitry-leaving those specifically assigned dedicated time-slots for digital data transmission (including video transmission).
- Option for user to select voice echo cancellation or digital-data transmission selectively on each time-slot for selective echo cancellation. This feature allows the user to use selected time-slots for data transmission to enable digital data/CCS signaling transmission.
- Transmission (data mode), while keeping the echo cancellation "ON" on the remaining time-slots (voice mode), on which echo is required to be cancelled.
- Meets ITU-T G.164, G.165, G.168 (2000/2002) requirements for echo cancellation.
- Stratum 3e clock for stable internal clock/holdover clock in the event of failure of any of the selected clock sources

### Highlights

- Provides voice echo cancellation of up to 128ms. bidirectional (near-end and far-end echo canceller) for 8 E1 Echo Cancellers.
- Custom user definable echo-tail displacement (echo tail off-set) between 0ms. to 512ms. This allows the user to cancel echo in both directions (near-end and far end), even in most difficult conditions i.e. excessive transmission delays that are common on VoIP GSM, CDMA, networks and satellite links
- Voice Quality Enhancement:
  - Removes background noise
  - Automatic level control (maintains VF levels)
  - Acoustic Echo Control
  - Adaptive listener Enhancement
- E1 link by-pass on power failure. This feature helps to maintain the link integrity event in the event of power failure
- The echo canceller supports fax/modem G.164 and G.165 (2100 Hz) tone disable
- User selected clock/synchronization option- Internal, External and Loop-timed clock
- Remote access through telnet over LAN/TCP-IP link (10/100BaseT)
- Local access through COM port (RS232 serial port)
- Easy-to-use text based CLI commands for management and configuration
- Adjustable gain/loss settings on all channels. Provides the user the flexibility to adjust and optimize the voice, transmit and receive levels.
- Non-linear processor with comfort noise insertion
- Fully independent 8 E1 (or T1) echo canceller
- **Remote Monitoring and Control:**
  - Remote access through telnet over LAN/TCP-IP link (10/100BaseT)
  - Local access through COM port (RS232 serial port)
- **Fault Recovery :** The echo canceller equipment offers fault recovery feature. It offers automatic by-pass upon power-supply failure (i.e. it offers E1 circuit by-pass in the event of power supply failure).
- Ensures echo canceller maintains excellent performance at all times in presence of tones or signals including DTMF tones.

## Application Diagrams

### E1 Echo Celler : VCL-EC™

To cancel the echoes at both ends (near-end and far-end) of the Network with one 128ms. bidirectional Echo Celler

#### Application 1

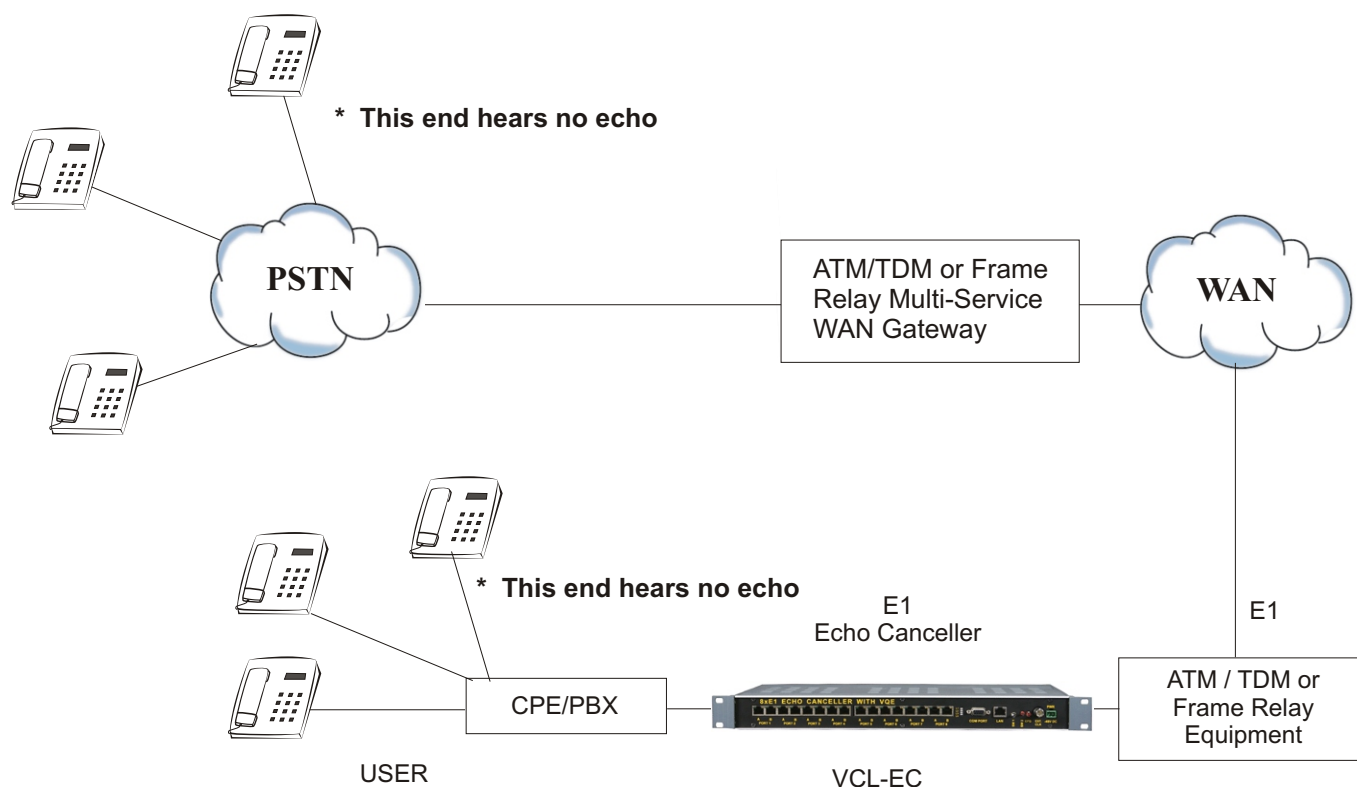

To cancel the echoes at both ends of the network with one 128ms. bidirectional Echo Celler with user programable Echo Tail Displacement (Echo Tail Off-set) Features

**Note:** The VCL-EC™ Echo Celler offers User Programable Echo Tail Displacement feature, User Definable Echo-Tail Displacement is selectable between 0ms. to 512ms. on the return-path. This feature allows the user to cancel echo-tails in BOTH directions (both near-end and far-end echo tails), even in most demanding conditions that are common on VoIP networks and satellite links.

## VCL-EC, 8 x VQE & E1 Echo Cancellor Shelf Description:

The VCL-EC, 8 x VQE and E1 Echo Cancellor is a 1U, 19-inch shelf, fitted with a back plane. The E1 interface, power input, alarm extension, COM Port, LAN and external clock are all accessed from the system front panel.

## VCL-EC, 8 x VQE & E1 Echo Cancellor

### Front View of the Shelf

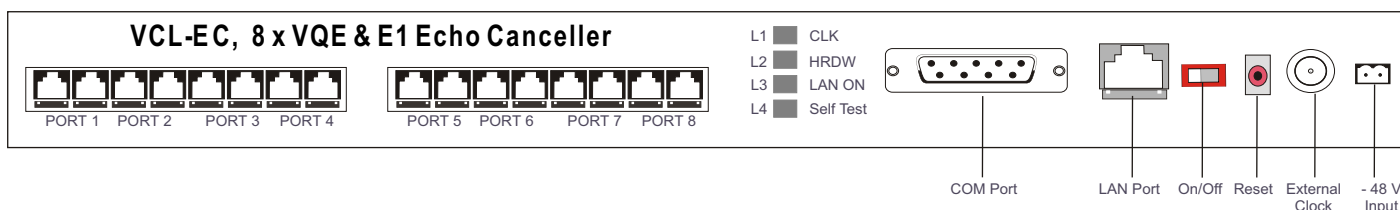

## Mechanical Specifications

Rack Mounting	Standard 19 Inch. DIN Rack
Height	44.00 mm.
Depth	260.00 mm.
Width	477.00 mm.
Weight	4.00 Kg. (8 xVQE & E1 Echo Cancellers per chassis)

## Clock

Internal	(Stratum 3 level)
Loop-timed	Port A / Port B (User Selectable)

## Compliance/Regulatory

<ul style="list-style-type: none"> <li>EMC FCC Part 15 Class 2</li> </ul>
<ul style="list-style-type: none"> <li>Operation ETS 300 019 Class 3.2</li> </ul>
<ul style="list-style-type: none"> <li>Storage ETS 300 019 Class 1.2</li> </ul>
<ul style="list-style-type: none"> <li>Transportation ETS 300 019 Class 2.3</li> </ul>
<ul style="list-style-type: none"> <li>CE</li> </ul>



## Technical Specifications

### E1 Interface at 2048 Kbps

Number of Interfaces	16, E1 Interfaces, 8-Input (RJ-45), 8-Output (RJ-45)
Line Rate	E1 - 2.048 Mbps
Line Code	HDB3 as per ITU-T G.703, G.704
Framing Format	As per ITU-T G.704: FAS, FAS+CRC-4, CAS or CAS+CRC-4
Facility Protection	Metallic bypass relays for failsafe operation in the event of power supply failure
PCM Encoding Law	A Law as per ITU-T G.711
Signaling Protocols	Pass-Through: Signaling protocols supported: <ul style="list-style-type: none"> <li>- 30B+D PRI ISDN (Euro ISDN) Signaling</li> <li>- 31B (31 voice channels) with out-of-band Signaling</li> <li>- SS7 Signaling (on any user selected time-slot)</li> <li>- R2 CAS Signaling</li> <li>- CAS, C5, CCS, Q50 (AB/CD)</li> <li>- C7, PRI ISDN (30B+D)</li> <li>- All Signaling options are User Selectable/User Programmable</li> </ul>
PCM Sampling Rate	8000 samples/sec
Bit Rate	2048 Kbps $\pm$ 50 ppm
Jitter Tolerance	As per ITU-T G.823
Output Jitter	< 0.05 UI (in the frequency range of 20Hz to 100 KHz)
Nominal Line Impedance	120 Ohms Balanced RJ 45
Nominal Pulse Width	244 ns
Pulse Mask	As per ITU (CCITT) Rec. G.703
Loss and recovery of frame alignment	As per clause 3 of ITU (CCITT) G.732
Loss and recovery of multiframe Alignment	As per clause 5.2 of ITU (CCITT) G.732

### Power Supply Specifications

Input DC Voltage	-48V DC (nominal)
Range of Input Voltage	-40V to -60V DC
Output Voltages	+3.3V
Maximum Full Load Output Current	4A at +3.3V
Input Voltage Reversal Protection	Provided in the Card
Over Current Protection	> 4A for +3.3V
Short Circuit Protection	Current limit - 4A. Recovers on removal of short
Under Voltage	< 2.9V
Over Voltage	3.7V
Efficiency at Full Load	>86%
Ripple at Full Load	<5mVrms
Spike at Full Load	<50mV

## Echo Cancellation

Echo Tail Cancellation	Up to 128ms. bidirectional (near-end and far-end)
Tone Disabler	As per ITU-T G.164, G.165
ERLE (Echo Return Loss Enhancement)	>35 dB (with 6dB ERL) at - 10 dBm0 >65 dB with NLP enabled
ERL (Echo Return Loss)	Selectable Threshold Levels Options: 0, 3, 6 dB
Transmit/Receive Levels (Programmable)	Selectable Levels Options: -12, -9, -6, -3, 0, +3,+6,+9
Comfort Noise Insertion	User Selectable-Enable/Disable
Local Monitoring and Control	RS232 serial interface for Management through a PC COM Port
Remote Monitoring and Control	Ethernet (10BaseT) interface for remote LAN Management and Control
Local and Remote Provisioning	CLI (text commands) and GUI
Front Panel Indicators	- In SYNC/Failure - LEDs for power on/off
Environmental-Operational	0° C to 50° C
Humidity	5% to 95%, non-condensing
Voice Quality	Acoustic Echo Control (AEC) Adaptive Noise Reduction (ANR) Adapting Listener Enhancement (ALE) Automatic Level Control (ALC) G.169

## Management Port Specifications 10BaseT LAN Management Port (with Telnet)

Network Interface	RJ-45 Ethernet 10BaseT or 100 BaseT-TX (auto sensing)
Compatibility	Ethernet Version 2.0 IEEE802.3
Protocols Supported	ARP, UDP/IP, TCP/IP, Telnet, ICMP, SNMP, DHCP, BOOTP, TFTP, Auto IP, SMTP and HTTP
LEDs	10Base-T & 100Base-TX Activity, Full/half duplex
Management	Serial login, Telnet login, GUI
EMI Compliance	<ul style="list-style-type: none"> <li>- Radiated &amp; conducted emissions - complies with Class B limits of EN55022:1998</li> <li>- Direct &amp; Indirect ESD - complies with EN55024:1998</li> <li>- RF Electromagnetic Field Immunity - complies with EN55024:1998</li> <li>- Electrical Fast Transient/Burst Immunity - complies with EN55024:1998</li> <li>- Power Frequency Magnetic Field Immunity - complies with EN55024:1998</li> <li>- RF Common Mode Conducted Susceptibility - complies with EN55024:1998</li> </ul>

## Ordering Information

Sr. #	Product Description	Part #
1.	VCL EC™ 8 x VQE & E1 Echo Cancellers Per Chassis	VCL-EC-E1-8

Note: \_\_\_\_\_

\_\_\_\_\_

\_\_\_\_\_

\_\_\_\_\_

\_\_\_\_\_

\_\_\_\_\_

\_\_\_\_\_

\_\_\_\_\_

\_\_\_\_\_

\_\_\_\_\_

\_\_\_\_\_

Technical specifications are subject to changes without notice.  
All brand name and trademarks are the property of their respective owners.  
Revision 08 - July 1, 2011

**COMARRA**

**E-Mail: [info@comarra.co.uk](mailto:info@comarra.co.uk)**  
**Website: <http://www.comarra.co.uk>**