

COMARRA

TELECOM TRANSMISSION SOLUTION



**VCL - 2/34 Mbps
PDH Multiplexer
E3, PDH Multiplexer**

Product Brochure & Data Sheet

COMARRA

E-Mail: info@comarra.co.uk

Web Site: <http://www.comarra.co.uk>

INDEX

S.No.	Particulars	Pg. No.
1.	Description - VCL-2/34 Mbps (PDH MULTIPLEXER)	3
2.	Features & Highlights	3
3.	External Interfaces	4
4.	Programming & Monitoring	6
5.	Technical Specifications	8



VCL - E3, 2/34 Mbps PDH Multiplexer

Product Description

VCL E3-2/34Mbps, PDH Multiplexer is a third order skip multiplexer / demultiplexer unit, based on PDH (Plesiochronous Digital Hierarchy) technology. It multiplexes sixteen 2.048Mbps (hereafter referred to as 2Mbps) E1 tributaries into a single 34.368Mbps (hereafter referred to as 34Mbps) E3 tributary. The multiplexer / demultiplexer also does the reverse processing i.e. demultiplexing a received 34Mbps stream into 16, 2Mbps E1 tributaries.

VCL-2/34 Mbps Multiplexer system consists of two VCL-2/34 Mbps terminals, one each at the local and remote ends, connected through a 34Mbps stream,

providing end to end services for sixteen, 2 Mbps streams. The VCL-2/34 Mbps PDH Multiplexer

Front View



provides 16, 2Mbps E1 electrical interfaces which are multiplexed to 1, ITU-T compliant E3, 34Mbps G.703 electrical interface.

Front View of Shelf

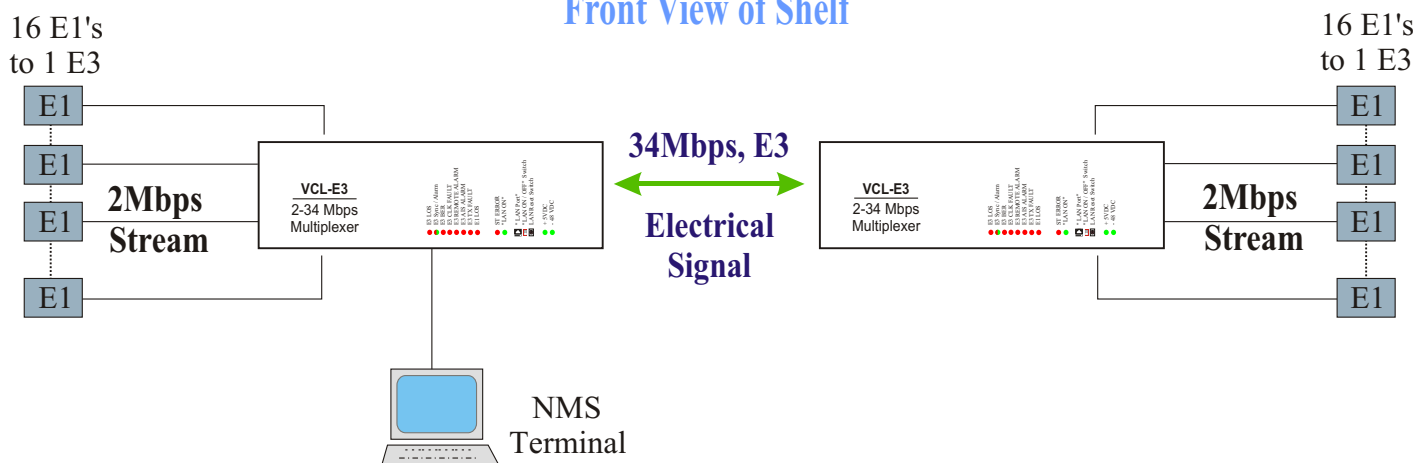

FEATURES & HIGHLIGHTS

- Single - card implementation
- Plug and Play Multiplexers
- Modular 2Mbps transmission units
- Standard CCITT (ITU-T) compliant interfaces
- Monitoring and control by CLI (Command Line Interface)
- TCP/IP Remote Access for monitoring alarms and management
- Extensive alarms and status indication facility

- Service bit monitoring and insertion
- Operates on nominal -48V DC input
- Distributed on-board power supply
- Microprocessor controlled with powerful diagnostic facilities
- Loopback facility for 34Mbps stream
- Stored program controlled
- Highly reliable and compact

EXTERNAL INTERFACES

VCL-E3 unit provides the following interfaces to the external world:

16, primary rate, 2Mbps, 120 balanced interface

1, third order, 34Mbps, 75 unbalanced interface

-48V input for VCL-2/34 on-board power supply

RS232 interface for connection to Local Management System, used for configuration and monitoring of the VCL-2/34 multiplexer.

NO/NC Dry contact Relay alarm.

Front View of Shelf

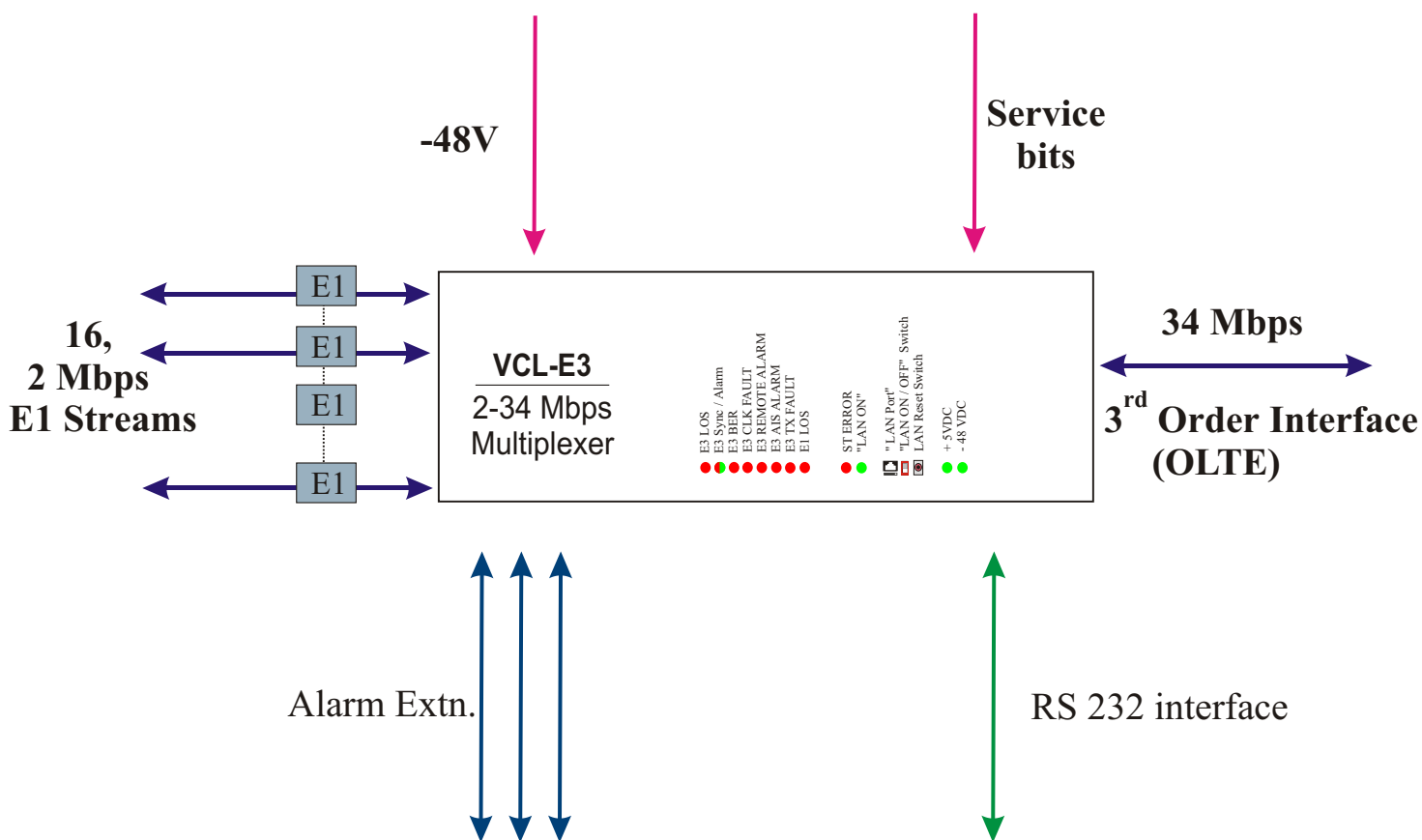

The front panel LEDs provide the following indications:

L1 - E3 LOS	L7- E3 TX FAULT
L2- E3 Sync / Alarm	L8- E1 LOS
L3- E3 BER	L9- ST ERROR
L4- E3 CLK FAULT	L10- "LAN ON"
L5- E3 REMOTE ALARM	L11- Positive 5V present
L6- E3 AIS ALARM	L12- Negative 48V input present
RJ-45 "LAN Port"	SW1 "LAN ON / OFF" Toggle Switch
	SW2 LAN Reset Switch

BACK PANEL OF E3, 2/34Mbps Multiplexer RJ-45 Version

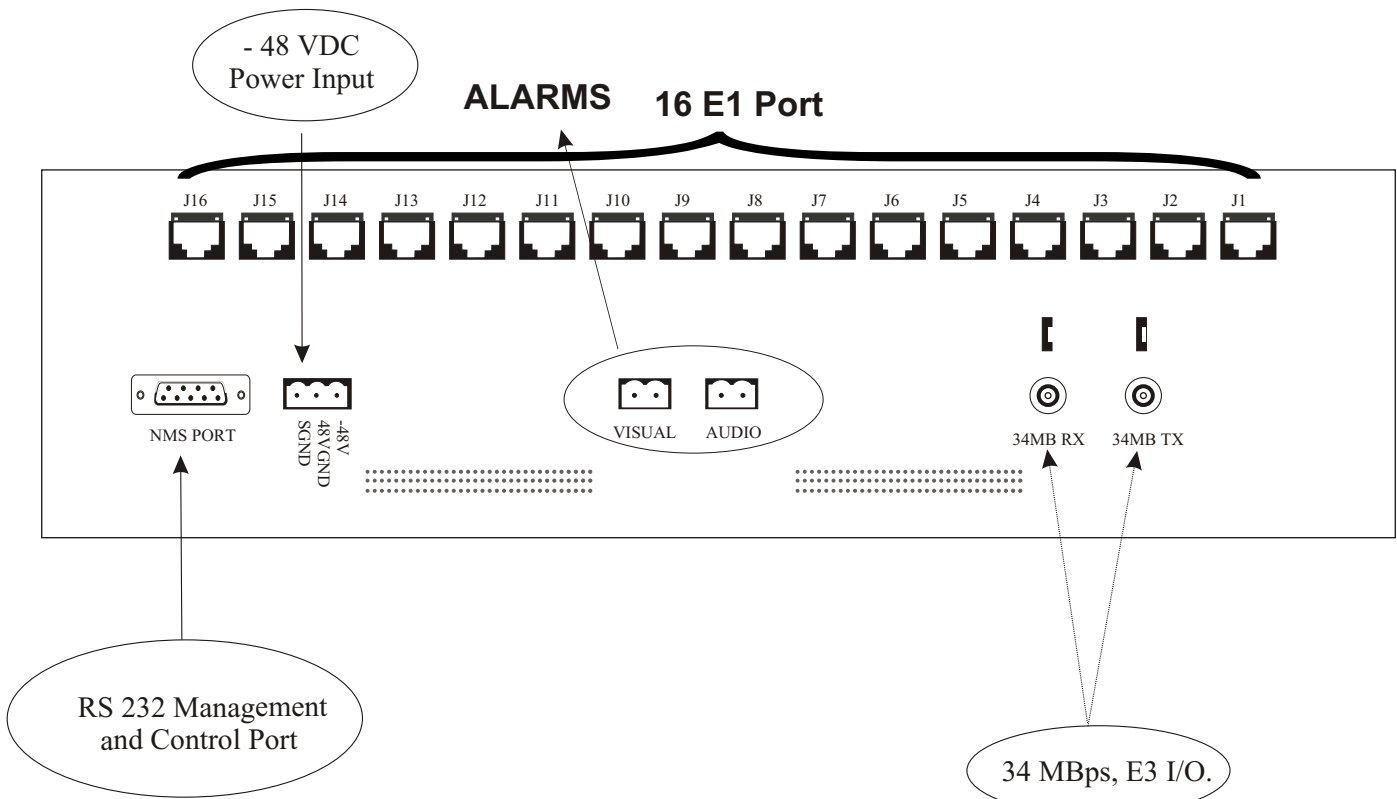

PROGRAMMING AND MONITORING

VCL-2/34 Mbps Multiplexer offers programming via an RS232 port for control and monitoring of the terminals. Multiplexer can be monitored and controlled using a PC with the Hyperterminal connected to the local terminal.

Programming Features

- Setting loopbacks on 2Mbps or 34Mbps
- Enabling or disabling 2Mbps channels
- Initiating self tests
- Alarm acknowledgment option

Status Monitoring

- Priority sequence of clock selection and current clock on which the system is working
- Status of alarm
- Presence or absence of loop-back on 34Mbps and 2Mbps streams
- Enabled / disabled status of 2Mbps channels
- Monitoring healthy / unhealthy state of micro controller and 2Mbps line interface units

Alarm Status Monitoring

- Loss of incoming signal at all 2Mbps ports
- Loss of incoming signal at 34Mbps port
- Loss of frame alignment at 34Mbps
- Remote Alarm at 34Mbps
- AIS at 34Mbps
- Excessive Error Rate at 34Mbps
- Status of audible alarm

Monitoring VCL-E3 via LED Indications

- Loss of signal at 2Mbps
- Loss of signal at 34Mbps
- Loss of frame alignment at 34Mbps
- Remote Alarm at 34Mbps
- AIS at 34Mbps
- Excessive Error Rate at 34Mbps
- +5V failure
- 48V input failure
- Processor unhealthy alarm
- Prompt Maintenance alarm

In addition to the above monitoring facilities, VCL-2/34Mbps Multiplexer is provided with LEDs on the front panel of the multiplexer, which indicate various fault conditions.

APPLICATION DIAGRAM OF VCL-2/34 Mbps PDH Multiplexer

VCL 2/34 Mbps multiplexer with Digital Microwave Radio

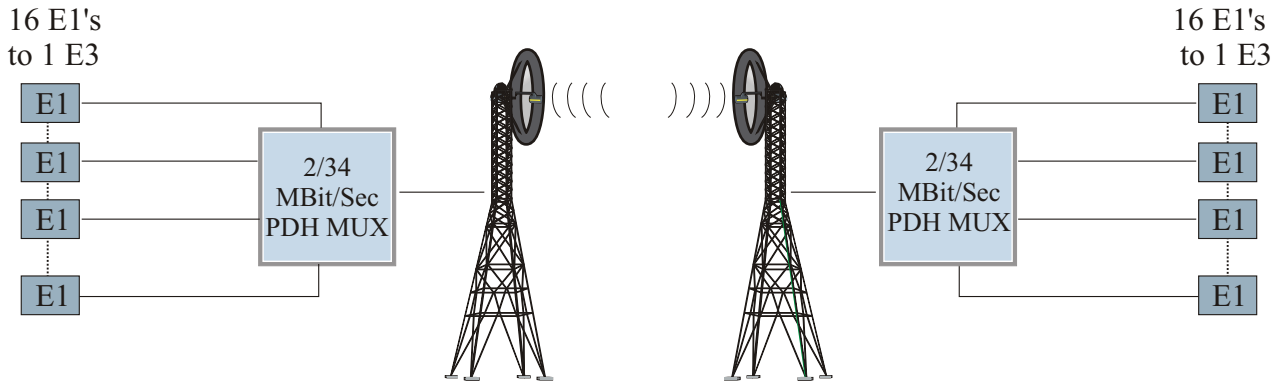

VCL 2/34 Mbps multiplexer with 34 Mbps OLTE (Optical Line Transmission Equipment)

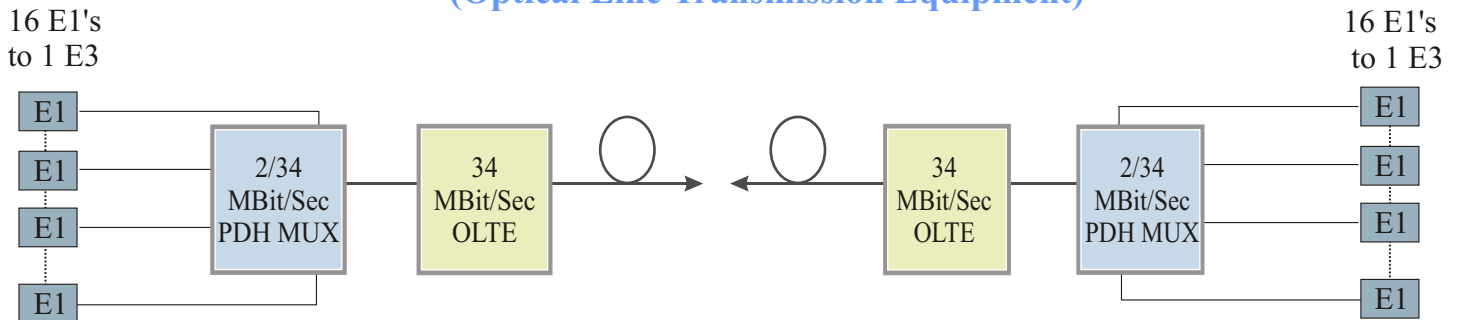

VCL 2/34 Mbps multiplexer - Internet Access Application

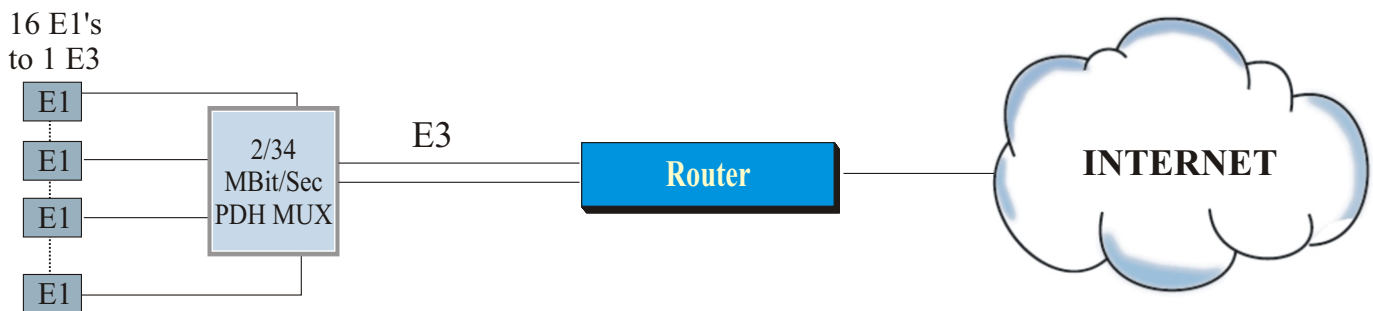

TECHNICAL SPECIFICATIONS

34Mbps, third order Interface

Number	1
Nominal bit rate	34368kbps
Bit rate tolerance	20ppm
Line code	HDB3
Frame structure	as per G.751
Interfaces	as per G.703
Connectivity	BNC connector (75 Ohms)
Cable	75 unbalanced
Permissible attenuation	12dB at 17184kHz

2Mbps primary rate interface

Number	16
Nominal bit rate	2048kbps
Bit rate tolerance	50ppm
Line code	HDB3
Frame structure	as per G.704
Interfaces	as per G.703
Connectivity	RJ-45 Female connector (120 Ohms)
Cable	120 balanced
Permissible attenuation	6dB at 1024 kHz

NMS (with Telnet)

xPort Specifications

Network Interface	RJ-45 Ethernet 10BaseT or 100BaseT-TX (auto sensing)
Compatibility	Ethernet Version 2.0 IEEE802.3
Protocols Supported	ARP, UDP/IP, TCP/IP, Telnet, ICMP, SNMP, DHCP, BOOTP, TFTP, Auto IP, SMTP and HTTP
LEDs	10Base-T & 100Base-TX Activity, Full/half duplex.
Management	Internal web server, SNMP (read only), Serial login, Telnet login
EMI Compliance	Radiated & conducted emissions - complies with Class B limits of EN 55022:1998 Direct & Indirect ESD - complies with EN55024:1998 RF Electromagnetic Field Immunity - complies with EN 55024:1998 Electrical Fast Transient/Burst Immunity - complies with EN55024:1998 Power Frequency Magnetic Field Immunity - complies with EN55024:1998 RF Common Mode Conducted Susceptibility - complies with EN55024:1998

Power Consumption :

Power Consumption	7.20 Watt
-------------------	-----------

Technical specification are subject to change without notice.

Revision 06. March 12th, 2006

COMARRA

E-Mail: info@comarra.co.uk

Website: <http://www.comarra.co.uk>