

# COMARRA

TELECOM TRANSMISSION SOLUTION



---

## VCL100CP STM-1 SDH Add-Drop Multiplexer

---

Product Brochure & Data Sheet

---

# COMARRA

E-Mail: [info@comarra.co.uk](mailto:info@comarra.co.uk)

Web Site: <http://www.comarra.co.uk>

---

## Introduction

Traditionally SDH was being used for providing high speed traffic due to its robust architecture and rapid protection schemes. As the traffic pattern changed, there was a need to support multiple services from the same equipment like integrated data transport, better network management etc. This necessitated evolution to Next-Generation SDH.

### STM-1 SDH Multiplexer with a choice of interfaces



VCL100CP

Next generation SDH/SONET has emerged as one of the most economical and technologically viable solution for transmitting both voice and data over carrier networks. This technology offers savings on investments power and space to service providers. The latest Multi Service Switching Platforms (MSSPs) and Multi Service Provisioning Platforms (MSPPs) speed up provisioning of new services and optimize network efficiency through better utilization of its network.

VCL100 provide a full range of solution in this evolving field of NG SDH/SONET. VCL100 family provides the unique advantage of carrying both data and voice over SDH/SONET. In addition to the cheaper solution provided by this family, these products have built in modularity, which allow easy upgradeability. This upgradeability feature allows the customer to evolve in "build-as-you-grow" concept. Along with the Network Management solution, the VCL100 family provides the following features:

- Easy network manageability
- Lower cost per line
- Easy upgradeability
- Carrying both data and voice over SDH/SONET

## Architectural Details

### Interfaces Available:

- VCL100CP operates at STM-1 (155.52 Mbps) aggregate level
- 14 E1s (or 8 E1) on base card
- 1/2 - port STM-1 or 21 / 28 E1 / DS1
- 3 x E3 / DS3
- 8 port 10/100Base Ethernet Card.
- The system supports SDH according to ITU-T standard G.707.

VCL100CP can be configured in various topologies such as linear, ring or mesh. VCL100CP uses SDH architecture, which by itself provide larger capacity, efficient use of fiber, quick provisioning, and a substantial saving in deployment and future maintenance cost.

## Key Features

### **Multi-service platform:**

VCL100CP supports both data and voice traffic.

### **Ethernet over SDH (EoS):**

Ethernet card complies with GFP and X.86 standards. Supports port-based and 802.1Q based VLAN, 802.1p priority, traffic filtering based on MAC Address/ network layer protocols. It supports LCAS, Lower and Higher Order Virtual Concatenation, Full/half duplex and auto-negotiation.

### **Flexibility:**

It can be configured in various topologies supporting both electric and optical interface. It can take modular cards, which would enable the customers to start small and grow as traffic demands scale. All interfaces are in front for easy access.

### **Protection:**

VCL100CP provides protection features using sub-network connection protection (SNCP) and MSP with switching time less than 50 ms.

### **Configuration:**

VCL100CP can be configured as add-drop multiplexers (ADM) and terminal multiplexers (TMUX). It can support diverse topologies like point-to-point, Bus topology and Ring topology.

### **Cross-connect capability:**

VCL100CP provides a completely non-blocking 4x4 STM-1 cross-connect at VC-12 granularity (252x252 VC 12s)

### **Automatic Topology discovery:**

VCL100CP has the ability to automatically discover nodes and trunks within the optical domain, and then intelligently provision the circuit accordingly. This eliminates cumbersome operator intervention and substantially reduces costs.

### **Miniature size:**

VCL100CP is one of the most compact STM-1 products available in the market, and provides an optimal solution for installation in 19-inch rack. VCL100CP is only 1U high and has a dense port configuration.

### **Synchronization**

Stratum-3/G.813 option 1 compliant timing and synchronization functions.

### **Laser protection:**

VCL100CP comes with SFP-based optical line interfaces with digital diagnostics capability for SFPs.

## System Overview

The VCL100CP Service Access Node is an ultra-compact and cost-effective customer premises bandwidth provisioning equipment designed to meet low or medium capacity bandwidth service demands. VCL100CP is part of a family of STM-1 Multi-Service Provisioning and Access Nodes as with all products in the family, the Service Access node also supports end-to-end provisioning and management of voice and data services across all the segments of the optical network - from the customer premises to the core. It combines innovative optical networking software with the intelligence of SDH to deliver a flexible solution to today's service providers.

### VCL100CP Chassis

VCL100CP provides miniature size architecture. VCL100CP can be installed in both 19" and 23" rack with suitable adapters.

The figure below shows the main interfaces in the VCL100CPchassis.

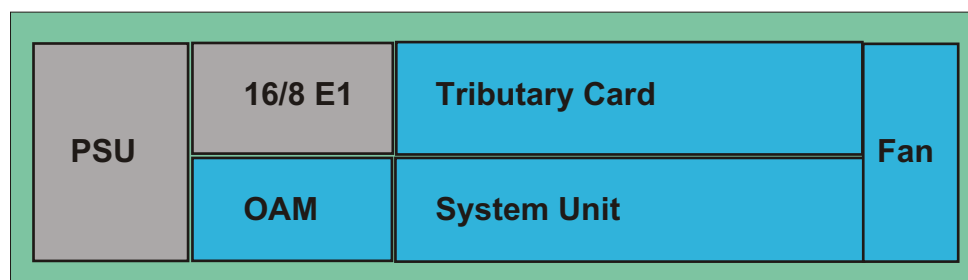

Figure 1: VCL100CP Chassis

## Aggregate Interface

The aggregate interface can be a 1 or 2 port STM-1 interface. VCL100CP aggregate interface supports both electrical and optical STM-1 interfaces. This has a built -in 4 x 4 STM-1 cross-connect at VC-12 granularity.

### Craft, Modem and Ethernet Management Interface

It provides RS-232 craft port, V.24/V.28 modem and 10/100 BaseT Ethernet interface. The Ethernet port is used for NMS purpose. VCL100CP provides engineering order-wire (EOW) support using E1/E2 bytes.

### Diagnostic, Clock and Alarm

VCL100CP allows external 2MHz or 2 Mbps timing signal inputs for synchronizing the input. Detailed synchronization procedure can found later in this system guide.

VCL100CP supports **potential free contacts** for extending the alarms. There are 7 alarms input and 4 alarms output.

## Tributary Cards

VCL100CP has one tributary slot, which can handle E1/DS1, E3/DS3, Ethernet or STM-1 o/e interfaces.

### **8/16/21/28 x E1/DS1 tributary card:**

Depending on the requirements VCL100CP can be provided with 8/16/21/28 port E1/DS1 card.

### **1/3 x E3/DS3 tributary card:**

VCL100CP can provide 1 or 3 port E3/DS3 support. VCL100CP carries the E3 traffic in an AU4 mode.

### **STM-1 o/e Tributary card:**

The lasers supported are S1.1, S1.2, L1.1 or L1.2 depending upon required reach of the link. We can software configure all STM-1 interfaces into the same mapping mode viz., AU3 or AU4, as the case maybe. STM-1e and 140 Mbps interfaces are software configurable on the same card.

### **8-port 10/100 Base-T Ethernet tributary card (ETC):**

The Ethernet data is carried on multiple VC-12's in granularities of 2 Mbps. Depending on the customer requirement each of the 8 ports in ETC can be configured to carry data in increments of 2 Mbps, such that the aggregate traffic bandwidth from ETC card is 155 Mbps. The ETC supports LCAS, GFP/ X.86, Lower and Higher Order Virtual Concatenation, Full/half duplex and auto-negotiation.

## Synchronization and timing

VCL100CP can derive its clock from the following source

- **Line-timed mode:** In this mode VCL100CP derives its clock from any one of the E1 tributaries or STM-1 signals.
- **Externally timed mode:** In this mode an external 2048 KHz or 2 Mbps signal could be used as the clock source
- **Holdover mode:** In this mode, VCL100CP uses the stored timing data to control the output frequency for a short duration (of around 24 hrs). Beyond this it uses its own internal oscillator in a free-running mode.

VCL100CP supports Synchronization Status Messaging (SSM) as per ITU-T standards. This is a messaging technique, which enables a SDH equipment to determine the derivation of a timing source. It uses overhead bytes contained within the SDH overhead (S1) for transmitting these messages. Thus when a failure occurs, elements communicate timing reconfiguration information across the network. This is used by VCL100CP for the purpose of synchronization.

VCL100CP provides a 2.048 M BITS clock output, which can be set to either a 2.048 MHz clock or a framed E1 data at 2.048 Mbps.

## Power Supply

VCL100CP is powered by a 48V dc power supply or 230V AC, which drives the various subsystems in it.

## Protection Features

VCL100CP provides the following protection features:

- VC-12 and VC-3 Path Protection Switching (LO/HO SNC as per G.841 §8)
- 1+1 linear APS (as per G.841)

## Application

VCL100CP in various configurations like TMUX, ADM and DXC, can be used in the access network to provide Fiber to the Curb/Fiber to the Building (FTTC/FTTB). This product is a highly reliable, easily manageable system, which comes at real cheap price.

### FTTC/FTTB

VCL100CP is an ideal platform to provide high-end data and voice requirement of clients. VCL100CP can be installed in customer's premise and can provide voice traffic requirement from 14 E1 to 42 E1. In addition VCL100CP can provide Ethernet connectivity. In the figure shown below, VCL100CP connect to the customer premise and carry the traffic through a STM-1 ring to be terminated in VCL100CP. VCL100CP can then be connected to central office terminal (COT) from where VCL100CP can be remotely configured. This architecture provides SNCP protection to the traffic.

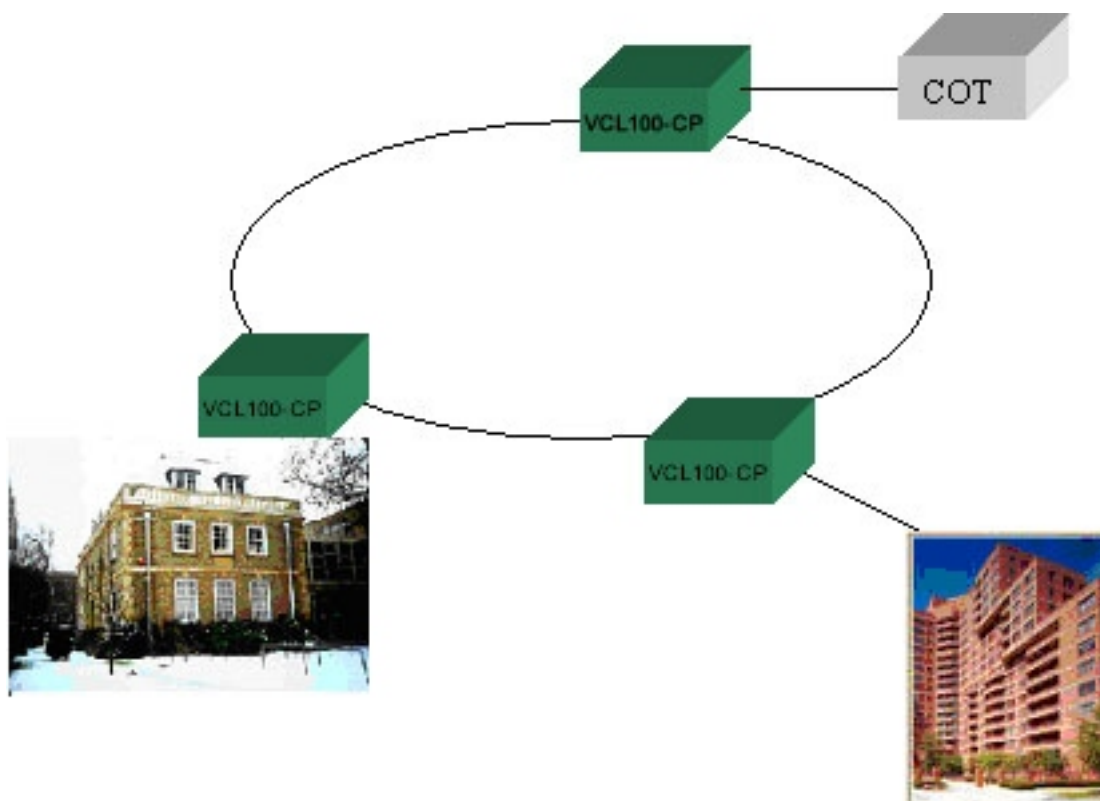

## Cellular Mobile Network

The cellular mobile network is evolving at a very fast pace. To keep up with the rapid pace at which the cellular network is evolving, the underlying SDH network, which provide E1 connectivity to the base stations (BTS) should be able to upgrade at a very fast pace. VCL100CP provides the ideal platform for this evolution. From as low as 14 E1 we could go upto 42 E1 terminations. VCL100CP transport the E1 signal reliably from BTS to base station controller (BSC).

One critical feature for cellular networks is the need for precise timing and synchronization. VCL100CP allows the user to access timing information from the line, external clock or internal stratum-3 source. In a line-timed mode, it derives its clock from any one of the E1 tributaries or STM-1 signals. In an externally timed mode, an external 2048 KHz or 2 Mbps signal could be used as the clock source. If none of these sources are available, VCL100CP goes into a holdover mode when it uses the stored timing data to control the output frequency for a short duration (of around 24 hrs). Beyond this it uses its own internal oscillator in a free-running mode. VCL100CP supports synchronization status messaging (SSM) for timing reconfiguration information.

The miniature size and low power consumption make VCL100CP an ideal choice for remote integration to base station.

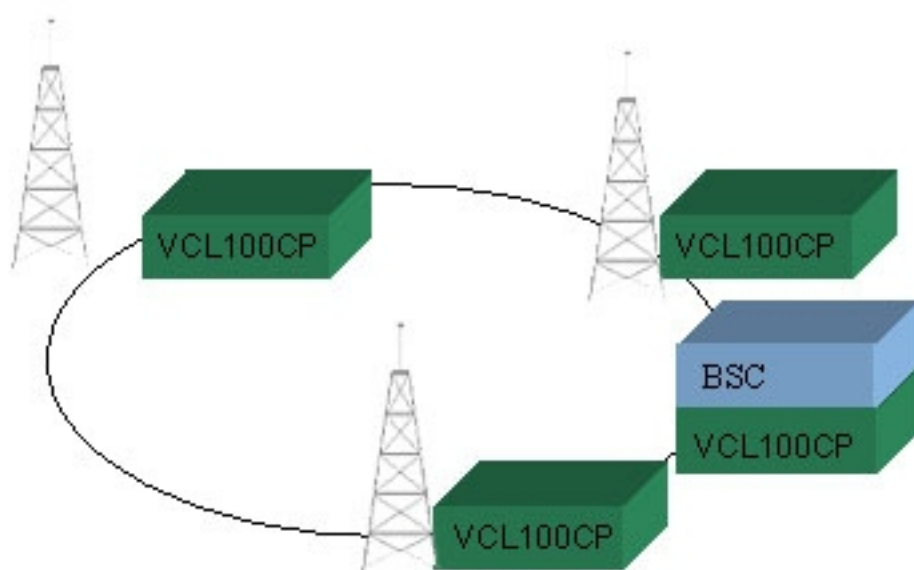

**Figure 3: Cellular Mobile Application**

## Software

VCL100CP can be managed locally using Network Element Software. Also we can centrally maintain large number of VCL100CP using Network Management Software.

Networks Element Software

Networks Element Software provide the following key features:

- Node-wise Operations & Maintenance
- User programmable severity levels for Alarms
- Node-wise Alarming & Remote Login.
- Performance monitoring as per the standard specifications (G.826).
- In-service monitoring of E1 tributaries.
- Supports full FCAPS functionality via web browser interface.

Networks Element Software allows user to configure all the above mentioned features using a standard Hyper Text Transfer Protocol (HTTP) based web browser. Networks Element Software makes the physical data connection using the Ethernet interface in the management interface module in VCL100CP. Networks Element Software also allows users to control remote nodes using the web browser interface. For this purpose, Networks Element Software uses DCC bytes in the STM-1 frame for carrying the management information to the remote node.

Networks Element Software allows open software interface using the Networks Element Software - SNMP software module.

VCL100CP comes with a point-and-click provisioning (PNCP) tool. This module enables customers to provision end-to-end circuits in a network that comprises all family of SDH products. For this users can enable node-resident software module Networks Element Software -NODE-PNCP, and the server-resident software module Networks Element Software -HOST-PNCP.

## NMS

VCL100CP provides support for a centralized network management through Networks Element Software. For this VCL100CP provides the following operation interfaces:

- 10/100 Mbps half-duplex LAN interface for NMS data connection to VCL100CP node (RJ45 connector)
- RS232C Craft interface for local Command Line Interface data connection
- 2 wire analog telephone interface for Engineering Order Wire (E1 or E2 bytes access) with omnibus calling



## Technical Specifications

### Network Details

Topology supported	Linear, Ring
Element Configuration	Element Configuration Terminal Multiplexers (TMUX) Add drop Multiplexers (ADM) Regenerator STM-1 cross-connect

### Aggregate Interface

2 x STM-1e/o
S 1.1,S1.2, L1.1, L1.2 (ITU-T G.957 compliant)

### Tributary Interface

16 / 28 x E1 / DS1
1/3 x E3/DS3
1/2 x STM-1e
1/2 x STM-1o
8 x 10/100 Base Ethernet

### Cross-connect

252 x 252 VC-12
Fully non-blocking
Line to line
Line to Tributary
Tributary to Line
Tributary to Tributary

## Timing and Synchronization

G.813 complaint

External 2 Mbps/ 2 MHz source

Internal and external timing interface (2 E1 BITS interface)

Internal G.703 complaint stratum-3 oscillator

SSM byte support

## Protection

SNCP

## Maintenance

Higher-order and lower order POH SDH alarms

Performance monitoring as per G.826 and G.784

Local and remote loop-back

Remote software download

## Management

Networks Element Software which support FCAPS feature

SNMP interface (for NMS)

RS-232 port (craft interface)

V.24/V.28 modem interface (for remote management)

In Band Channel control

10/100 Base T (RJ45) Management Interface

External alarm interface and indicators

## Order wire and user data channel

E1/E2 byte for express order wire

7 input alarms and 4 output alarms

F1 byte for user data channel

## Power Supply

-48 V dc or 230V AC

Consumption: < 35 W

## Environmental

Operating Temperature: 0° to 50° C

Relative Humidity: 10 90 %, non-condensing

## Physical dimension

H x W x D: 44 mm x 445 mm x 250 mm

19" rack mountable

Technical specification are subject to change without notice.  
Revision 06. March 12th, 2006

# COMARRA

**E-Mail: [info@comarra.co.uk](mailto:info@comarra.co.uk)**

**Website: <http://www.comarra.co.uk>**